



**PERFORMANCE TESTING IN ACCORDANCE WITH  
AAMA/WDMA/CSA 101/I.S.2/A440-11 (NAFS 2011), CSA A440S1-09 & CSA A440S1-17  
AAMA/WDMA/CSA 101/I.S.2/A440-17 (NAFS 2017) & CSA A440S1:19**

<b>Manufactured under licence</b>
<b>Dalmen Windows &amp; Doors</b> 5360, Ste Catherine Street (Box 220) St-Isidore, Ontario K0C 2B0

<b>REPORT AI-04915-G1 (Reissue-02)</b>
--

<b>TEST REPORT SUMMARY</b>	
<b>Product type</b>	<b>Awning Window</b>
<b>Product series/model</b>	<b>NC65STH HES OUT</b>
<b>Primary designator</b>	<b>Class AW – PG70: Size tested 1500 x 1500 mm (~59 x 59 in) - Type AP</b>
<b>Optional secondary designator</b>	<b>Positive Design pressure (DP) = 3360 Pa (~70.18 psf)</b> <b>Negative design pressure (DP) = -3360 Pa (~-70.18 psf)</b> <b>Water penetration resistance test pressure = 720 Pa (~15.04 psf)</b> <b>Canadian air infiltration/ exfiltration level = A3 Level (NAFS-11) / Passed (NAFS-17)</b>
<b>Option(s)</b>	<b>Sill face drainage</b>

*See CLEB laboratory Inc. complete report AI-04915-G1 (Reissue-02) for test specimen description and detailed test results*

<b>Test completion date</b>	2019-11-26	<b>Number of pages</b>	8 pages & 1 appendix
<b>Report date</b>	2019-11-29	<b>Revision date</b>	2020-12-23

**Prepared by:**



**Digitally Signed by:**  
**Jason Michaud, Tech.**  
 Fenestration Testing Department  
 CLEB laboratory Inc.

**Approved by:**



**Digitally Signed by:**  
**Jean Miller, P.Eng.**  
 Manager, Fenestration Testing Department  
 CLEB laboratory Inc.

LABORATORY, FIELD TESTING AND ADVISORY SERVICES FOR THE BUILDING ENVELOPE  
 30 YEARS STRONG, UL AND CLEB SERVING CUSTOMERS ACROSS NORTH AMERICA AND BEYOND

**CHICAGO**  
 US Headquarters  
 750 Anthony Trail  
 Northbrook, IL 60062

**MONTREAL**  
 Canada Headquarters  
 1320 Lionel-Boulet Blvd  
 Varennes, QC J3X 1P7

**QUEBEC**  
 420 Charest East Blvd  
 Suite 300  
 Quebec, QC G1K 8M4

**OTTAWA**  
 29 Capital Drive  
 Suite 200  
 Ottawa, ON K2G 0E7

**TORONTO**  
 7, Underwriters Road  
 Toronto, ON  
 M1R 3A9

**NEW YORK**  
 747 Third Avenue  
 2nd Floor  
 New York, NY 10017

**TABLE OF CONTENTS**

**1.0 INTRODUCTION ..... 1**

**2.0 DESCRIPTION OF THE SPECIMEN(S) TESTED ..... 1**

**3.0 ALTERATION(S)..... 3**

**4.0 TEST BENCH INFORMATION ..... 3**

**5.0 RESULTS OF PERFORMANCE TESTS ..... 4**

**6.0 CONCLUSION..... 8**

**7.0 REVISION LOG ..... 8**

**APPENDIX: DRAWINGS, SEALANT, DRAINAGE DETAILS & BILL OF MATERIALS**

---

*The results relate only to the product(s) in this report. This report shall not be reproduced, except in full, without the written approval of CLEB laboratory Inc.*

## 1.0 INTRODUCTION

---

CLEB laboratory Inc. was retained by "**METRA S.p.A**" to test a fenestration product according to the performance levels in the *AAMA/WDMA/CSA 101/I.S.2/A440-11 (NAFS 2011) Standard and its Canadian supplements CSA A440S1-09 & CSA A440S1-17 and the AAMA/WDMA/CSA 101/I.S. 2/A440-17 (NAFS 2017) Standard and its Canadian supplement CSA A440S1:19*. "**METRA S.p.A**" has requested and authorized that this original test report issued under their name, be reissued to "**DALMEN WINDOWS & DOORS**". The sample components and manufacturing are documented in section 2.0.

Note concerning the use of units of measurement in this report:

*According to the AAMA/WDMA/CSA 101/I.S.2/A440 Standard, the use of SI (metric) units is the standard, while IP (Imperial) values given in parentheses are for reference purposes only, and are inexact rounded values. Section 5.0 contains testing results converted to IP units for the sake of convenience only. The only exception to using SI values is in the Performance Grade (PG) portion of the product designation.*

Note concerning drawings:

*The drawings reviewed for the production of this report are stamped and are on file at CLEB laboratory Inc. The availability of individual drawings will be at the discretion of the client.*

## 2.0 DESCRIPTION OF THE SPECIMEN(S) TESTED

---

**Model**

NC65STH HES OUT

**Product type**

AP – (Awning window)

**Operation mode**

Outswing

**Drawing Package (Appendix)**

NC 65 STH HES OUT AWNING WINDOW (elevation and sections A-A & B-B), NC 65 STH HES OUT AWNING WINDOW (installation details and sections A-A & B-B), NC 65 STH HES OUT (SECTIONS), NC 65 STH HES OUT (PROFILES), NC 65 STH HES OUT (ACCESSORIES), NC 65 STH HES OUT (HARDWARE), NC 65 STH HES OUT (GASKETS), NC 65 STH HES OUT (MACHINING FOR HARDWARE), NC 65 STH HES OUT (MACHINING FOR ASSEMBLY) , Use and Maintenance guide to METRA windows and doors page 21 (cleaning and maintenance of aluminium windows and doors)

**Date(s) of sample reception**

2019-11-07

---

*The results relate only to the product(s) in this report. This report shall not be reproduced, except in full, without the written approval of CLEB laboratory Inc.*

**Date(s) of testing**

2019-11-11, 2019-11-13, 2019-11-14, 2019-11-19, 2019-11-20, 2019-11-21, 2019-11-22, 2019-11-28

**Test specimen installation (test buck)**

Material: Laminated wood (~2" x 6"); sill base is doubled up to accommodate through-frame drainage option. See drawing *NC 65 STH HES OUT AWNING & CASEMENT WINDOWS - SILL DETAIL SHOWING DRAINAGE PATH*

R.O. clearances: 6 mm (0.24")

Fastening: See drawing *NC 65 STH HES OUT AWNING WINDOW*

Sealing detail: Backer rod and sealant between test buck and specimen on exterior perimeter only. Wooden test buck frame wrapped with elastomeric membrane and sealed with compatible sealant. Sealant in the frame installation screw holes.

**Frame**

Material: Extruded aluminum

Joinery type: Mitre-cut, mechanical assembly with corner keys, pins and epoxy

Reinforcement: No reinforcement

Weatherstripping: See drawing *NC 65 STH HES OUT (GASKETS)*

Sealant: Sealant at the assembly of the frame mitered corners. Sealant over the frame assembly pins.

Sealant in the corners of the interior gasket frame groove, before vulcanized corner gasket installation.

See drawing *NC 65 STH HES OUT (MACHINING FOR ASSEMBLY) – Gasket fitting on frame MG786D*.

Drainage: See drawing *NC 65 STH HES OUT (MACHINING FOR ASSEMBLY) – Position of the water Drainage – Frames – Solution with awning or casement opening*

Glazing: None

Overall dimensions: 1500 mm (59.06") W x 1500 mm (59.06") H

**Sash**

Material: Extruded aluminum

Joinery type: Mitre-cut, mechanical assembly with corner keys, pins and epoxy

Reinforcement: No reinforcement

Weatherstripping: See drawings *NC 65 STH HES OUT (GASKETS)* and *NC 65 STH HES OUT (MACHINING FOR ASSEMBLY) – Gasket fitting on frame MG786D, Gasket fitting on frame MG796D, Gasket fitting on sash MG786D*. Exterior gasket is cut out (notched) for hinge clearance.

Sealant: Sealant at the assembly of the sash mitered corners. Sealant over the sash assembly pins. Sealant in the corners of the exterior gasket frame groove before vulcanized corner gasket installation. Sealant on the corners of the central gasket groove before vulcanized corner gasket installation. Sealant at the corners of the exterior glazing gasket junctions before installing the glass unit. Sealant at the interior and exterior side gasket junctions (on the sash/ glazing stops). See drawings *(MACHINING FOR ASSEMBLY) – Gasket fitting on frame MG796D & Gasket fitting on sash MG786D*.

Drainage: See drawing *NC 65 STH HES OUT (MACHINING FOR ASSEMBLY) – Ventilation Sashes & Pressure compensation position Sashes*

Glazing: Double glazed sealed unit (25.4 mm) / Nominal glass thickness : Exterior : 6 mm/ Interior: 6 mm / Air space gap: 13.4 mm / Type of glass: Exterior: Clear tempered/ Interior: Clear tempered / Type of spacer: Aluminum rectangular/ Type of sealant: Dual-sealed / Type of filling gas: Air / Glass retention: Glazing stops / Glazing seals: glazing gasket on the exterior face (dry glazing) and glazing gasket on the interior face (dry glazing) / Grid description: None / Setting blocks: (4) at the lower rail, (3) per stile and (3) at the upper rail/ Daylight opening: 1282 mm W x 1282 mm H

Overall dimensions: 1465 mm (57.68") W x 1465 mm (57.68") H

---

*The results relate only to the product(s) in this report. This report shall not be reproduced, except in full, without the written approval of CLEB laboratory Inc.*

**Screen**

None

**Hardware**

See hardware descriptions and quantity on drawings *NC 65 STH HES OUT (HARDWARE)*. Part number and manufacturer/ supplier information for hardware components provided by the client.

Operating handle with gear-box driven push-out/pull-in mechanisms and multi-point locking with (2) corner transmissions, (3) link bars, (2) fixed locking points, (5) adjustable locking points and (7) fixed keepers. The test sample was also fitted with (3) butt hinges.

**3.0 ALTERATION(S)**

---

Alteration(s) performed in the laboratory on tested specimen to meet the reported performances: None.

**4.0 TEST BENCH INFORMATION**

---

Test bench identification: TB-AWS-02

The calibration of this test bench was done as per Article 9.0 of *ASTM E283, Standard Test Method for Rate of Air Leakage through Exterior Windows, Curtain Walls and Doors*, and *ASTM E331 Standard Test Method for Water Penetration of Exterior Windows, Skylights, Doors and Curtain Walls by Uniform Static Air Pressure Difference* and *ASTM E547 Standard Test Method for Water Penetration of Exterior Windows, Skylights, Doors and Curtain Walls by Cycling Static Air Pressure Difference*. The last calibration of this test bench and related equipment was performed in July, 2019.

---

*The results relate only to the product(s) in this report. This report shall not be reproduced, except in full, without the written approval of CLEB laboratory Inc.*

## 5.0 RESULTS OF PERFORMANCE TESTS

SPECIFICATIONS	TEST RESULTS
<p><b><u>Ease of operation test</u></b>  <b><u>NAFS-11 U.S. (only) requirements:</u></b>            Force to initiate motion:            R – LC – CW – AW &lt; 155 N (~34.85 lbf)            Force to maintain motion:            R – LC &lt; 100 N (~22.48 lbf)            CW – AW: reported only            R-LC-CW Force to latch &lt; 100 N (~22.48 lbf)</p> <p><b><u>NAFS-11 Canadian (only) requirements &amp; NAFS-17 requirements for U.S. &amp; Canada:</u></b>            Force to initiate motion:            R – LC – CW – AW &lt; 155 N (~34.85 lbf)            Force to maintain motion:            R – LC &lt; 100 N (~22.48 lbf)            CW – AW &lt; 135 N (~30.35 lbf)            R-LC-CW Force to latch &lt; 100 N (~22.48 lbf)            AAMA/WDMA/CSA 101/I.S.2/A440-11 par. 9.3.1.            A440S1-09 &amp; A440S1-17 Canadian Supplement par. 5.2            AAMA/WDMA/CSA 101/I.S.2/A440-17 par. 9.3.1.            A440S1-19 Canadian Supplement par. 5.3            ASTM-E2068-00 (2008)</p>	<p><b>Passed Class AW Classification</b></p> <p>Measured to initiate = 18 N (~4 lbf)            Measured to maintain = 71 N (~16 lbf)            Measured to latch = Not applicable</p>
<p><b><u>U.S. Air Leakage Resistance Test</u></b>            R – LC – CW Classifications:  <math>Q_{inf} \leq 1.5 \text{ l/s-m}^2 @ 75 \text{ Pa}</math> (~ ≤ 0.3 cfm/ft<sup>2</sup> @ 1.57 psf)            AW Classification:  <math>Q_{inf} \leq 0.5 \text{ l/s-m}^2 @ 300 \text{ Pa}</math> (~ ≤ 0.1 cfm/ft<sup>2</sup> @ 6.27 psf)</p> <p><b><u>Canadian air infiltration/exfiltration levels</u></b>            R – LC – CW Classifications:            A2: <math>Q \leq 1.5 \text{ l/s-m}^2 @ 75 \text{ Pa}</math> (~ ≤ 0.3 cfm/ft<sup>2</sup> @ 1.57 psf)            A3: <math>Q \leq 0.5 \text{ l/s-m}^2 @ 75 \text{ Pa}</math> (~ ≤ 0.1 cfm/ft<sup>2</sup> @ 1.57 psf)            AW Classification:            A2: <math>Q \leq 0.5 \text{ l/s-m}^2 @ 300 \text{ Pa}</math> (~ ≤ 0.1 cfm/ft<sup>2</sup> @ 6.27 psf)            A3: <math>Q \leq 0.5 \text{ l/s-m}^2 @ 300 \text{ Pa}</math> (~ ≤ 0.1 cfm/ft<sup>2</sup> @ 6.27 psf)            AAMA/WDMA/CSA 101/I.S.2/A440-11 par. 9.3.2            A440S1-09 &amp; A440S1-17 Canadian Supplement par. 5.3            ASTM-E283-04 (2012)</p>	<p><b>Class AW – U.S. Requirements (NAFS-11)</b></p> <p><b>A3 Level –Canadian Requirements (NAFS-11)</b></p> <p>Surface: 2.25 m<sup>2</sup> (~24.22 ft<sup>2</sup>)</p> <p><math>Q_{inf} = 0.47 \text{ l/s-m}^2 @ 300 \text{ Pa}</math> (~0.09 cfm/ft<sup>2</sup> @ 6.27 psf)  <math>Q_{exf} = 0.45 \text{ l/s-m}^2 @ 300 \text{ Pa}</math> (~0.09 cfm/ft<sup>2</sup> @ 6.27 psf)</p>
<p><b><u>Air Leakage Resistance Test</u></b>            R – LC Classifications:  <math>Q_{inf} \leq 1.5 \text{ l/s-m}^2 @ 75 \text{ Pa}</math> (~ ≤ 0.3 cfm/ft<sup>2</sup> @ 1.57 psf)            Canadian air infiltration/exfiltration levels:            A2: <math>Q \leq 1.5 \text{ l/s-m}^2 @ 75 \text{ Pa}</math> (~ ≤ 0.3 cfm/ft<sup>2</sup> @ 1.57 psf)            A3: <math>Q \leq 0.5 \text{ l/s-m}^2 @ 75 \text{ Pa}</math> (~ ≤ 0.1 cfm/ft<sup>2</sup> @ 1.57 psf)            CW Classification:  <math>Q \leq 0.5 \text{ l/s-m}^2 @ 75 \text{ Pa}</math> (~ ≤ 0.1 cfm/ft<sup>2</sup> @ 1.57 psf)            AW Classification:  <math>Q_{inf} \leq 0.5 \text{ l/s-m}^2 @ 300 \text{ Pa}</math> (~ ≤ 0.1 cfm/ft<sup>2</sup> @ 6.27 psf)  <math>Q_{exf} \leq 0.5 \text{ l/s-m}^2 @ 75 \text{ Pa}</math> (~ ≤ 0.1 cfm/ft<sup>2</sup> @ 1.57 psf)            AAMA/WDMA/CSA 101/I.S.2/A440-17 par. 9.3.2            A440S1-19 Canadian Supplement par. 5.4            ASTM-E283-04 (2012)</p>	<p><b>Class AW – Passed (NAFS-17)</b></p> <p>Surface: 2.25 m<sup>2</sup> (~24.22 ft<sup>2</sup>)</p> <p><math>Q_{inf} = 0.47 \text{ l/s-m}^2 @ 300 \text{ Pa}</math> (~0.09 cfm/ft<sup>2</sup> @ 6.27 psf)  <math>Q_{exf} = 0.21 \text{ l/s-m}^2 @ 75 \text{ Pa}</math> (~0.04 cfm/ft<sup>2</sup> @ 1.57 psf)</p>

The results relate only to the product(s) in this report. This report shall not be reproduced, except in full, without the written approval of CLEB laboratory Inc.

<p><b>Water Resistance Test</b>  No water infiltration under a minimum pressure differential:  Class R: 140 Pa (~2.92 psf)  Class LC: 180 Pa (~3.76 psf)  Class CW: 220 Pa (~4.59 psf)  Class AW: 390 Pa (~8.15 psf)  AAMA/WDMA/CSA 101/I.S.2/A440-11 par. 9.3.3.  A440S1-09 &amp; A440S1-17 Canadian Supplements par. 5.4  AAMA/WDMA/CSA 101/I.S.2/A440-17 par. 9.3.2  A440S1-19 Canadian Supplement par. 5.5  Classes R, LC &amp; CW: ASTM-E547-00 (2009 &amp; 2016)  Class AW: ASTM-E547-00 (2009 &amp; 2016) &amp; ASTM-E331-00 (2009 &amp; 2016)</p>	<p><b>Class AW – U.S. &amp; Canadian Requirements</b></p> <p>No water infiltration under the minimum test pressure for the Class.</p> <p>No water infiltration at an optional test pressure differential of:</p> <p><b>580 Pa (~12.11 psf)</b>- U.S. &amp; Canadian Requirements  <b>720 Pa (~15.04 psf)</b> - Canadian requirements only</p>
<p><b>Life Cycle Testing (AW Classification)</b></p> <p>The test sequence is the following :</p> <p><u>Air Infiltration Test</u>  AAMA/WDMA/CSA 101/I.S.2/A440-11&amp;17 par. 7.3.5, ASTM-E283-04 (2012) &amp; AAMA 910-10; 3.1.2</p> <p><u>Water Resistance Test</u>  AAMA/WDMA/CSA 101/I.S.2/A440-11&amp;17 par. 7.3.5, ASTM-E547-00 (2009) &amp; ASTM E-331-00 (2009) &amp; AAMA 910-10; 3.1.3</p> <p><u>Vent Cycling Test (First Half)</u>  2000 cycles of sash open/close, including the locking hardware. AAMA 910-10; 3.1.4 &amp; 3.1.5</p> <p><u>Misuse Testing</u>  3.6.6.2 Balance Arm Load Test  3.6.6.3 Vent Lateral Racking Test  AAMA 910-10; 3.1.7 &amp; 3.6.6</p> <p><u>Vent Cycling Test (Second Half)</u>  2000 cycles of sash open/close, including the locking hardware. AAMA 910-10; 3.1.8 &amp; 3.1.9</p> <p><u>Post Vent Cycling Air Infiltration Test</u>  AAMA/WDMA/CSA 101/I.S.2/A440-11&amp;17 par. 7.3.5, ASTM-E283-04 &amp; AAMA 910-10; 3.1.11</p> <p><u>Post Vent Cycling Water Resistance Test</u>  AAMA/WDMA/CSA 101/I.S.2/A440-11&amp;17 par. 7.3.5, ASTM-E547-00 (2009) &amp; ASTM E-331-00 (2009) et AAMA 910-10; 3.1.12</p> <p><u>Thermal Cycling</u>  The test specimen was subjected to 6 thermal cycles per AAMA 501.5-07 (Test Method for Thermal Cycling of Exterior Walls). AAMA 910-10; 3.1.13</p>	<p><b>Passed Class AW (NAFS-11 &amp; NAFS-17)</b></p> <p><math>Q_{inf} = 0.37 \text{ l/s-m}^2 @ 300 \text{ Pa} (\sim 0.07 \text{ cfm/ft}^2 @ 6.27 \text{ psf})</math>  <math>Q_{exf} = 0.32 \text{ l/s-m}^2 @ 300 \text{ Pa} (\sim 0.06 \text{ cfm/ft}^2 @ 6.27 \text{ psf})</math>  <math>Q_{exf} = 0.15 \text{ l/s-m}^2 @ 75 \text{ Pa} (\sim 0.03 \text{ cfm/ft}^2 @ 1.57 \text{ psf})</math></p> <p>No water infiltration at an optional test pressure differential of 720 Pa (~15.04 psf)</p> <p>All operating/ locking parts were lubricated with white lithium grease every 500 cycles during the first half of the life cycling test. Hinges were not lubricated, nor was there any other maintenance performed on the specimen.</p> <p>There was no damage to fasteners, hardware parts, support arms, actuating mechanisms or any other damage that would cause the window to be inoperable.</p> <p>All operating/ locking parts were lubricated with white lithium grease every 500 cycles during the second half of the life cycling test. Hinges were not lubricated, nor was there any other maintenance performed on the specimen.</p> <p><math>Q_{inf} = 0.36 \text{ l/s-m}^2 @ 300 \text{ Pa} (\sim 0.07 \text{ cfm/ft}^2 @ 6.27 \text{ psf})</math>  <math>Q_{exf} = 0.31 \text{ l/s-m}^2 @ 300 \text{ Pa} (\sim 0.06 \text{ cfm/ft}^2 @ 6.27 \text{ psf})</math>  <math>Q_{exf} = 0.15 \text{ l/s-m}^2 @ 75 \text{ Pa} (\sim 0.03 \text{ cfm/ft}^2 @ 1.57 \text{ psf})</math></p> <p>No water infiltration at an optional test pressure differential of 720 Pa (~15.04 psf)</p> <p>High temperature= 82°C (180°F)  Low temperature= -18°C (0°F)  No damage observed</p>

The results relate only to the product(s) in this report. This report shall not be reproduced, except in full, without the written approval of CLEB laboratory Inc.



<p><b>Uniform Load Deflection Test (L/175) at DP40</b> AAMA/WDMA/CSA 101/I.S.2/A440-11&amp;17 par. 7.3.5, ASTM-E283-04 &amp; AAMA 910-10; 3.1.14 &amp; ASTM-E330-02 (2010)</p> <p><b>Post Thermal Cycling Air Infiltration Test</b> AAMA/WDMA/CSA 101/I.S.2/A440-11&amp;17 par. 7.3.5, ASTM-E283-04 (2012) &amp; AAMA 910-10; 3.1.15</p> <p><b>Post Thermal Cycling Water Resistance Test</b> AAMA/WDMA/CSA 101/I.S.2/A440-11&amp;17 par. 7.3.5, ASTM-E547-00 (2009) &amp; ASTM E-331-00 (2009) &amp; AAMA 910-10; 3.1.16</p> <p><b>Uniform Load Structural Test at 1.5x DP40 (STP40)</b> AAMA/WDMA/CSA 101/I.S.2/A440-11&amp;17 par. 7.3.5, et la spécification AAMA 910-10; 3.1.17, ASTM-E330-02 (2010) &amp; ASTM-E330-14</p>	<p>Member deflection does not exceed the limit of L/175 at a design pressure (DP) of 1920 Pa (~40.10 psf)</p> <p><math>Q_{inf} = 0.47 \text{ l/s-m}^2 @ 300 \text{ Pa} (\sim 0.09 \text{ cfm/ft}^2 @ 6.27 \text{ psf})</math>  <math>Q_{exf} = 0.45 \text{ l/s-m}^2 @ 300 \text{ Pa} (\sim 0.09 \text{ cfm/ft}^2 @ 6.27 \text{ psf})</math>  <math>Q_{exf} = 0.21 \text{ l/s-m}^2 @ 75 \text{ Pa} (\sim 0.04 \text{ cfm/ft}^2 @ 1.57 \text{ psf})</math></p> <p>No water infiltration at an optional test pressure differential of 720 Pa (~15.04 psf)</p> <p>Permanent deformation does not exceed the limit of 0.2% (L) at a structural test pressure (STP) of 2880 Pa (~60.15 psf)</p>
<p><b>Uniform Load Deflection Test</b> Member deflection at a minimum design pressure (DP) and at optional DP: Class R: 720 Pa (~15.04 psf) – Reported only Class LC: 1200 Pa (~25.06 psf) – Reported only Class CW: Limited to L/175 at 1440 Pa (~30.08 psf) Class AW: Limited to L/175 at 1920 Pa (~40.10 psf) AAMA/WDMA/CSA 101/I.S.2/A440-11 par. 9.3.4 AAMA/WDMA/CSA 101/I.S.2/A440-17 par. 9.3.4 ASTM-E330-02 (2010) &amp; ASTM-E330-14</p>	<p><b>DP 70 – Class AW</b></p> <p>Net deflection measured on the lower rail: 0.69 mm @ -1920 Pa (~0.03" @ -40.10 psf) 0.59 mm @ +1920 Pa (~0.02" @ +40.10 psf) 1.04 mm @ -3360 Pa (~0.04" @ -70.18 psf) 0.97 mm @ +3360 Pa (~0.04" @ +70.18 psf) Allowed ≤ 7.72 mm (~0.30")</p>
<p><b>Uniform Load Structural</b> Permanent deformation is limited at a minimum structural test pressure (STP) and at optional STP of: Class R: ≤ 0.4% (L) at 1080 Pa (~22.56 psf) Class LC: ≤ 0.4% (L) at 1800 Pa (~37.59 psf) Class CW: ≤ 0.3% (L) at 2160 Pa (~45.11 psf) Class AW: ≤ 0.2% (L) at 2880 Pa (~60.15 psf) AAMA/WDMA/CSA 101/I.S.2/A440-11 par. 9.3.4 AAMA/WDMA/CSA 101/I.S.2/A440-17 par. 9.3.4 ASTM-E330-02 (2010) &amp; ASTM-E330-14</p>	<p><b>STP 70 – Class AW</b></p> <p>Permanent deformation measured on the lower rail: 0.04 mm @ -2880 Pa (~0.00" @ -60.15 psf) 0.01 mm @ +2880 Pa (~0.00" @ +60.15 psf) 0.02 mm @ -5040 Pa (~0.00" @ -105.26 psf) 0.02 mm @ +5040 Pa (~0.00" @ +105.26 psf) Allowed ≤ 2.70 mm (~0.11")</p>
<p><b>Forced-Entry Resistance</b> All windows shall be tested according to ASTM F588-07 &amp; ASTM F588-14 Grade 10. AAMA/WDMA/CSA 101/I.S.2/A440-11 par. 9.3.5 AAMA/WDMA/CSA 101/I.S.2/A440-17 par. 9.3.5</p>	<p><b>Passed Grade 40</b></p> <p><math>T_1=10 \text{ min.}, L_1=1334 \text{ N} (\sim 300 \text{ lbf}), L_2=667 \text{ N} (\sim 150 \text{ lbf}) \&amp; L_3=267 \text{ N} (\sim 60 \text{ lbf})</math></p>
<p><b>Sash/ Leaf Torsion Test</b> Deflection of the unrestrained corner of an unglazed sash &lt; 33.3 x (sash area in m<sup>2</sup>) under a load of 70 N (~15.74 lbf) AAMA/WDMA/CSA 101/I.S.2/A440-11 par. 7.3.4.2 AAMA/WDMA/CSA 101/I.S.2/A440-17 par. 7.3.5.2</p>	<p><b>Passed Class AW</b></p> <p>Deflection under a load of 70 N (~15.74 lbf): Allowed deflection = 71.5 mm (2.81") Measured deflection = 45.0 mm (1.77")</p>

The results relate only to the product(s) in this report. This report shall not be reproduced, except in full, without the written approval of CLEB laboratory Inc.



<p><b><u>Sash/leaf Load Test on Latch Rail</u></b>  Deflection of the center of the span of the latch rail under a concentrated load of 135 N (~30.35 lbf) parallel and perpendicular to the plane of the sash (both directions) &lt;1.5 mm (0.06")  AAMA/WDMA/CSA 101/I.S.2/A440-11 par. 9.3.6.4.3  AAMA/WDMA/CSA 101/I.S.2/A440-17 par. 9.3.6.4.3</p>	<p><b>Passed Class AW – unglazed sash</b></p> <p>Allowed parallel: 1.5 mm (0.06")  Measured parallel: 0.31 mm (0.01")  Allowed perpendicular: 1.5 mm (0.06")  Measured perpendicular: 0.40 mm (0.02")</p>
<p><b><u>Insect Screen Test</u></b>  <u>Canadian (only) requirements:</u>  Insect screens shall be tested in accordance with ASTM E1748-95(09) in the outward direction only under a load of 60 N (~13 lbf).  A440S1-09 &amp; A440S1-17 Canadian Supplements par. 5.1  A440S1-19 Canadian Supplement par. 5.2</p>	<p>No screen supplied with the product.</p>

---

*The results relate only to the product(s) in this report. This report shall not be reproduced, except in full, without the written approval of CLEB laboratory Inc.*

## 6.0 CONCLUSION

---

Based on the tests results, the fenestration product described in this report meets the requirements of the *AAMA/WDMA/CSA 101/I.S.2/A440-11 (NAFS 2011) Standard and its Canadian supplements CSA A440S1-09 & CSA A440S1-17 and the AAMA/WDMA/CSA 101/I.S. 2/A440-17 (NAFS 2017) Standard and its Canadian supplement CSA A440S1:19*, regarding performance testing.

Detailed assembly drawings showing wall thickness of all members, corner construction and hardware application are on file and have been compared to the sample submitted.

The above results were secured by using the designated test methods and they indicate compliance with the performance requirements of the referenced specification. The test records from this evaluation will be retained for a minimum of four (4) years from the date of report issuance. This report does not constitute certification of this product, which may only be granted by a certification agency.

*Note on the Limitation of Liability:*

*Due care was taken in performing the testing sequence and in reporting the results related to the test specimen received for evaluation. Through acceptance of this report, the Client agrees to exempt CLEB laboratory Inc. employees and owners from all liability claims and demands arising from any matter related to or concerning the quality and execution of the performance evaluation contained in this report.*

## 7.0 REVISION LOG

---

Rev. #	Date	Page(s)	Revision(s)
--------	------	---------	-------------

---

*The results relate only to the product(s) in this report. This report shall not be reproduced, except in full, without the written approval of CLEB laboratory Inc.*

## **APPENDIX**

### **DRAWINGS, SEALANT, DRAINAGE DETAILS & BILL OF MATERIALS**

---

*The results relate only to the product(s) in this report. This report shall not be reproduced, except in full, without the written approval of CLEB laboratory Inc*

NC 65 STH HES OUT AWNING WINDOW

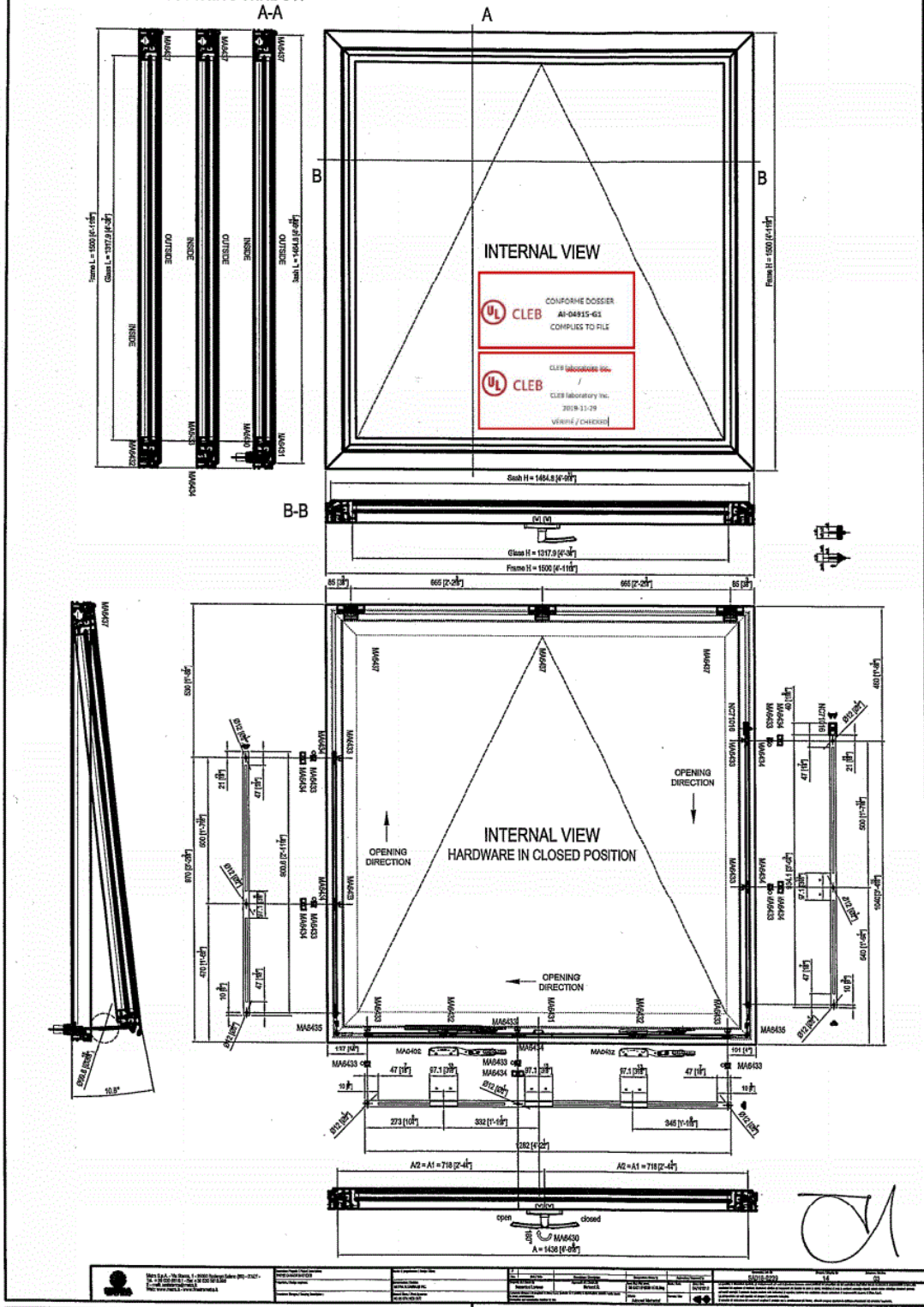

The results relate only to the product(s) in this report. This report shall not be reproduced, except in full, without the written approval of CLEB laboratory Inc

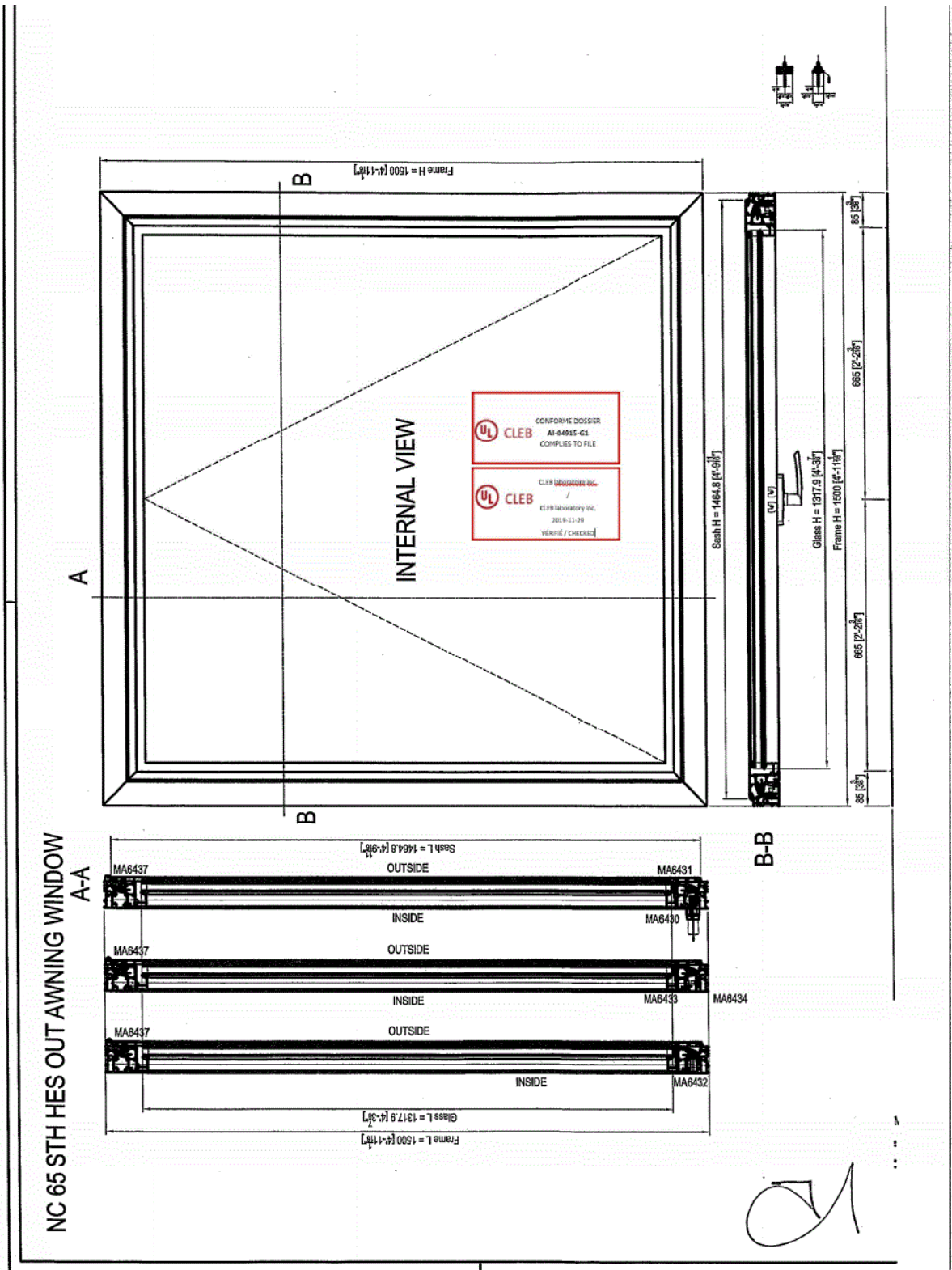

The results relate only to the product(s) in this report. This report shall not be reproduced, except in full, without the written approval of CLEB laboratory Inc

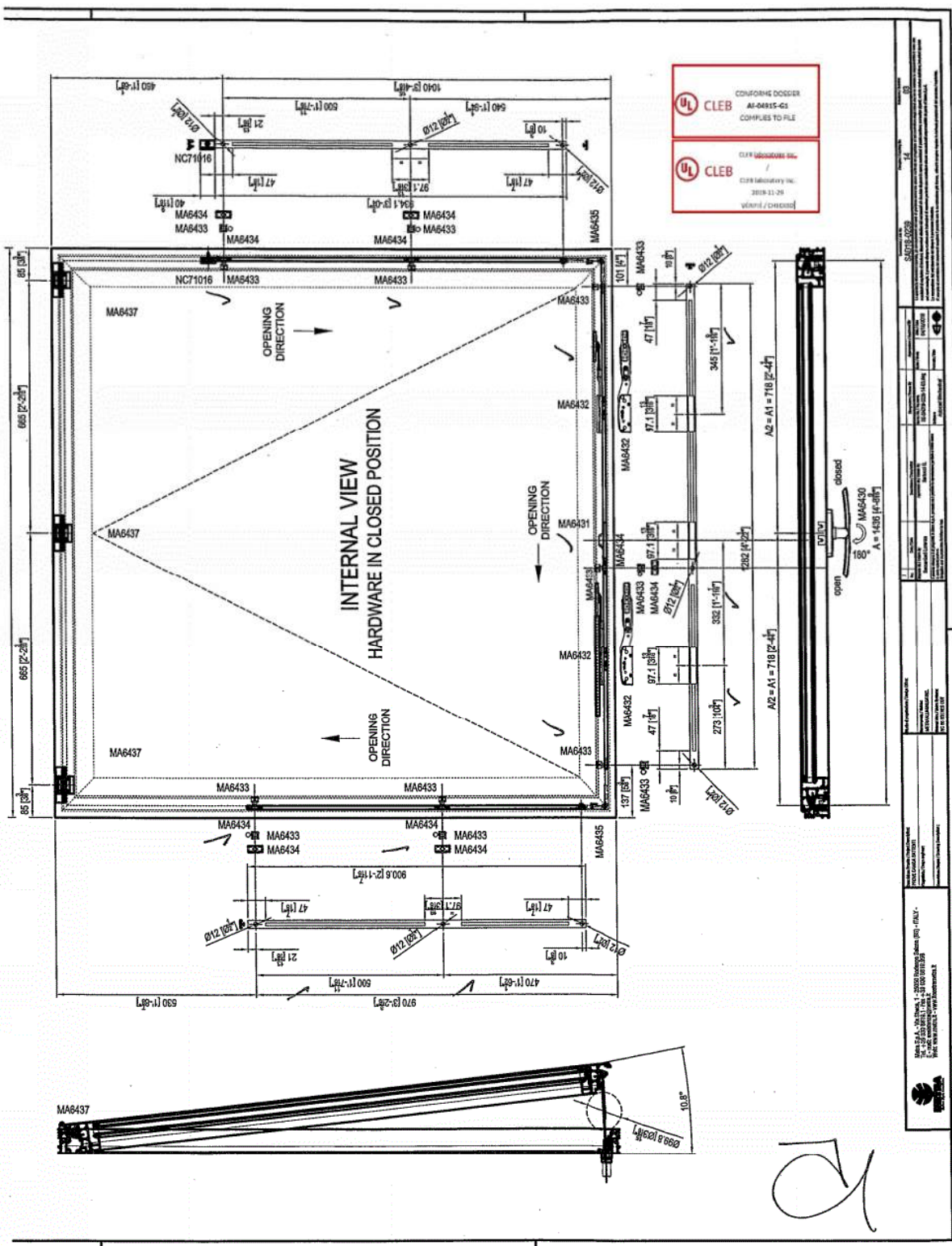

The results relate only to the product(s) in this report. This report shall not be reproduced, except in full, without the written approval of CLEB laboratory Inc



NC 65 STH HES OUT AWNING WINDOW

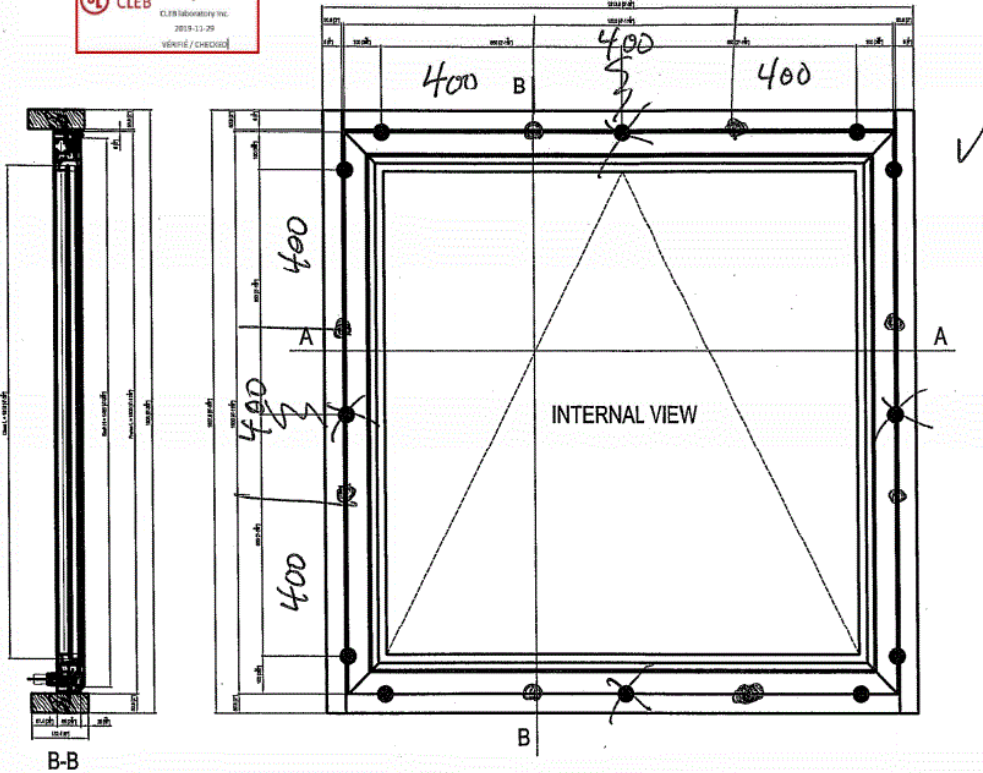

	Marked by: <b>UL</b>	Model: <b>NC 65 STH HES OUT AWNING WINDOW</b>	Date: <b>2020-12-23</b>	Version: <b>02</b>	Page: <b>11</b>
	Marked by: <b>UL</b>	Model: <b>NC 65 STH HES OUT AWNING WINDOW</b>	Date: <b>2020-12-23</b>	Version: <b>02</b>	Page: <b>11</b>

The results relate only to the product(s) in this report. This report shall not be reproduced, except in full, without the written approval of CLEB laboratory Inc





# SECTIONS

DS-SAD-0239-13 revE

*The results relate only to the product(s) in this report. This report shall not be reproduced, except in full, without the written approval of CLEB laboratory Inc*



INSIDE

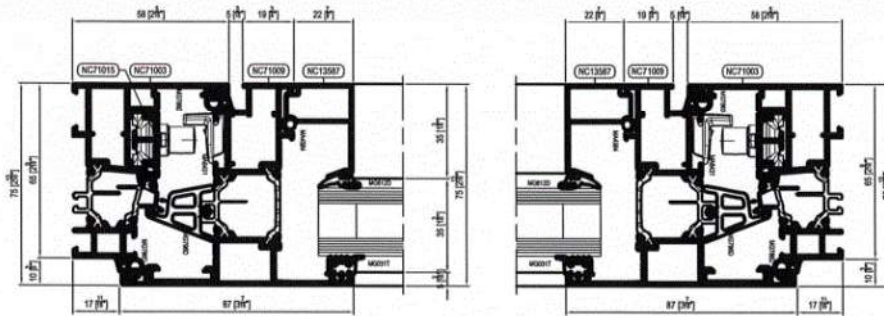

OUTSIDE

DS-SAD-0239-14 revH

The results relate only to the product(s) in this report. This report shall not be reproduced, except in full, without the written approval of CLEB laboratory Inc



 **CLEB** CONFORME DOSSIER  
AI-04915-G1  
CONPLIES TO FILE

 **CLEB** CLEB LABORATOIRES INC.  
/  
CLEB laboratory inc.  
2019-11-29  
VÉRIFIÉ / CHECKED

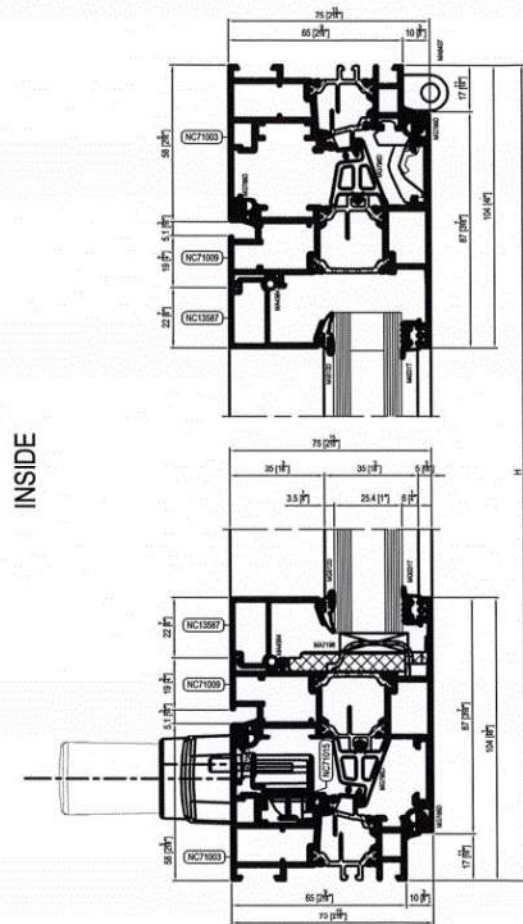

OUTSIDE

INSIDE

DS-SAD-0239-14 revH

The results relate only to the product(s) in this report. This report shall not be reproduced, except in full, without the written approval of CLEB laboratory Inc



# PROFILES

DS-SAD-0239-13 revE

*The results relate only to the product(s) in this report. This report shall not be reproduced, except in full, without the written approval of CLEB laboratory Inc*

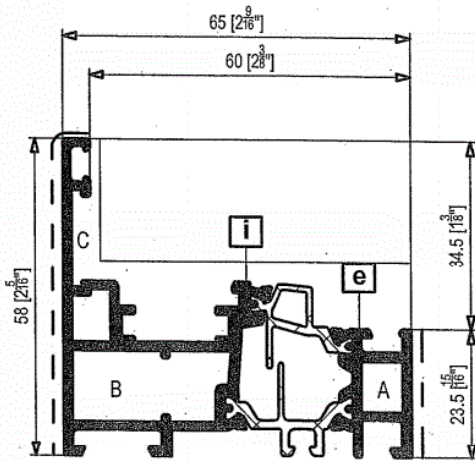

NC71003		$\frac{1}{2} K$ $\frac{1}{2} V$	$S_{x,cm^2}$ $S_{y,cm^2}$	USE
PERIMETER	350 [13.78]	8.308 [0.2]	2.147 [0.131]	Frame
WIPED SURFACE	81.5 [3.21]	24.317 [0.964]	6.421 [0.382]	AESTHETIC LINES BL
	A	B	C	D
	MA2806	MA2807 ( MA5550 )	MA4081	
	MA2806	MA2807	MA4081	
	MA2806 ( MA2809 )	MA2807 ( MA5550 )	MA4081	
	MA2840 ( MA2884 )	MA2841 ( MA5550 )		

COMPONENTS

SHAPE	CODE	OUT PERIMETER	EXPOSED SURFACE
	NC71002	124 [4 7/8]	23.5 [9/8]
	NC71001	278 [10 9/16]	63 [2 3/4]
	PF0014		
	PF0013		

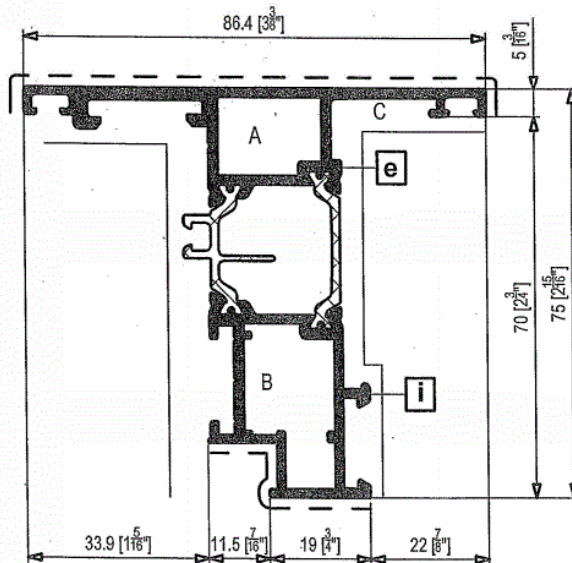

NC71009		$\frac{1}{2} K$ $\frac{1}{2} V$	$S_{x,cm^2}$ $S_{y,cm^2}$	USE
PERIMETER	427 [16.81]	30.826 [1.212]	8.136 [0.495]	Sash
WIPED SURFACE	127 [5]	18.267 [0.719]	4.938 [0.246]	AESTHETIC LINES BL
	A	B	C	D
	MA7227	MA7228 ( MA5550 )	MA2811 MA7187	
	MA7227	MA7228	MA2811 MA7187	
	MA7227 ( MA2884 )	MA7228 ( MA5550 )	MA2811 MA7187	

COMPONENTS

SHAPE	CODE	OUT PERIMETER	EXPOSED SURFACE
	NC71008	189 [7 4/8]	40 [1 5/8]
	NC71007	286 [11 1/4]	92 [3 5/8]
	PF0011		
	PF0013		

DS-SAD-0239-13 rev E

The results relate only to the product(s) in this report. This report shall not be reproduced, except in full, without the written approval of CLEB laboratory Inc



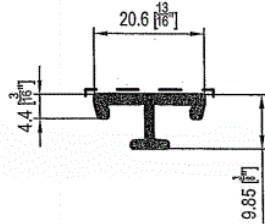

NC71015		$I_x$ cm <sup>4</sup> $I_y$ cm <sup>4</sup>	$S_x$ cm <sup>3</sup> $S_y$ cm <sup>3</sup>	USE
PARAMETER	90 [3.15]	0.064 [0.002]	0.095 [0.003]	Closing rod ✓
WEAR SURFACE	20.6 [0.81]	0.221 [0.005]	0.214 [0.013]	

UL CLEB  
CONFORME DOSSIER  
AI-04915-G1  
COMPLIES TO FILE

UL CLEB  
CLEAR LABORATORY INC.  
ELES laboratory inc.  
2019-11-29  
VÉRIFIÉ / CHECKED

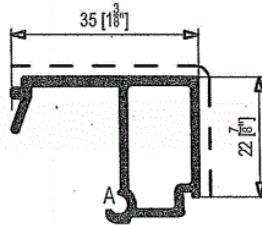

NC13587		$I_x$ cm <sup>4</sup> $I_y$ cm <sup>4</sup>	$S_x$ cm <sup>3</sup> $S_y$ cm <sup>3</sup>	USE
PARAMETER	148 [5.83]	1.698 [0.041]	0.791 [0.049]	Glass stop
WEAR SURFACE	65 [2.17]	1.303 [0.031]	0.778 [0.047]	AESTHETIC LINES BL
	A	B	C	D
	MG1530 MA4564			

DS-SAD-0239-13 revE

The results relate only to the product(s) in this report. This report shall not be reproduced, except in full, without the written approval of CLEB laboratory Inc



# ACCESSORIES





DS-SAD-0239-13 revE

*The results relate only to the product(s) in this report. This report shall not be reproduced, except in full, without the written approval of CLEB laboratory Inc*



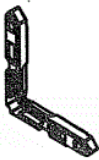
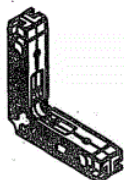

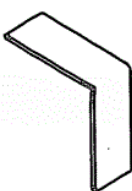
ITEM LIST

CODE	DESCRIPTION	MATERIAL	IMAGE
MA2806	CORNER CLEAT	DIE-CAST ALUMINIUM	
MA2807	CORNER CLEAT	DIE-CAST ALUMINIUM	
MA2811	CORNER CLEAT	VARIOUS	
MA4081	ALIGNMENT CORNER CLEAT	ALUMINIUM	
MA5550	ZAMAK WINDOW PIN	ZAMAK	

UL CLEB CONFORME DOSSIER AI-04915-G1 COMPLIES TO FILE

UL CLEB CLEAR (Accessories Inc.) CLEB Laboratory Inc. 2019-12-29 vérifié / checked

✓

✓

✓

✓

✓

DS-SAD-0239-13 revE

The results relate only to the product(s) in this report. This report shall not be reproduced, except in full, without the written approval of CLEB laboratory Inc







# HARDWARE

DS-SAD-0239-13 revE

*The results relate only to the product(s) in this report. This report shall not be reproduced, except in full, without the written approval of CLEB laboratory Inc*

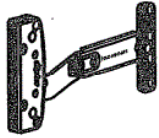

ITEM LIST

CODE	DESCRIPTION	MATERIAL	IMAGE
MA6430	HANDLE FOR OUTWARD OPENING	PLASTIC - STEEL	
MA6431	MOVEMENT DEVICE FOR HANDLE	STEEL	
MA6432	LEVER MECHANISM FOR OTWARD OPENING	STEEL	
MA6433	KEEPER	ZAMAK	
MA6434	ADJUSTABLE LOCKING POINT	STEEL	

 CONFORME DOSSIER  
 AI-04915-G1  
 COMPLIES TO FILE

 CLEB LABORATORY INC.  
 CLEB Laboratory Inc.  
 2019-11-29  
 VERIFIÉ / CHECKED



✓  
 ✓  
 ✓  
 ✓  
 ✓  

DS-SAD-0239-13 revE

The results relate only to the product(s) in this report. This report shall not be reproduced, except in full, without the written approval of CLEB laboratory Inc



ITEM LIST

CODE	DESCRIPTION	MATERIAL	IMAGE
MA6435	ANGULAR TRANSMISSION	STEEL	
MA6437	HINGE	VARIOUS	

 CONFORMS DOSSIER  
 AI-64915-G1  
 CONFORMS TO FILE  
  
 CLEB Laboratory Inc.  
 2019-11-29  
 WORKED / CHECKED



DS-SAD-0239-13 revE

The results relate only to the product(s) in this report. This report shall not be reproduced, except in full, without the written approval of CLEB laboratory Inc







# GASKETS

DS-SAD-0239-13 revE

*The results relate only to the product(s) in this report. This report shall not be reproduced, except in full, without the written approval of CLEB laboratory Inc*



ITEM LIST

CODE	DESCRIPTION	MATERIAL	IMAGE
MG031T	EXTERNAL GLAZING GASKET	EPDM	
<del>MG612D</del> MG613D	INTERNAL GLAZING GASKET 3/3.5	EPDM	
MG786D	INTERNAL RABBET GASKET	EPDM	
MG796D	CENTRAL GASKET	EPDM	



✓

✓

✓

✓





DS-SAD-0239-13 rev E

The results relate only to the product(s) in this report. This report shall not be reproduced, except in full, without the written approval of CLEB laboratory Inc



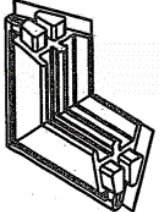

ITEM LIST

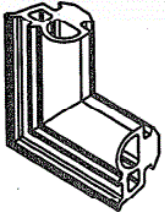
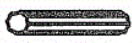
CODE	DESCRIPTION	MATERIAL	IMAGE
MA7198	GLASS SHIMMING BASE FOR SASHES	NYLON	
			✓
MA9327	VULCANISED CORNER FOR MG796D	EPDM	
			✓
MA5407	INTERNAL VULCANISED CORNER FOR MG786D	EPDM	
			✓
MA4564	GLASS STOP GASKET IN PCS	EPDM	
			✓

DS-SAD-0239-13 rev E

The results relate only to the product(s) in this report. This report shall not be reproduced, except in full, without the written approval of CLEB laboratory Inc





# MACHINING FOR HARDWARE

DS-SAD-0239-13 revE

*The results relate only to the product(s) in this report. This report shall not be reproduced, except in full, without the written approval of CLEB laboratory Inc*



Machining for handle installation

Handle with 104 mm [4 1/8"] interaxis

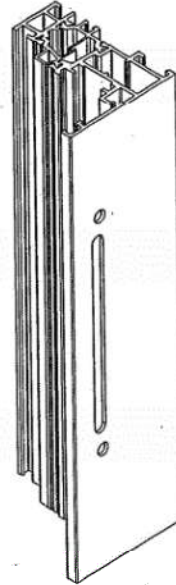
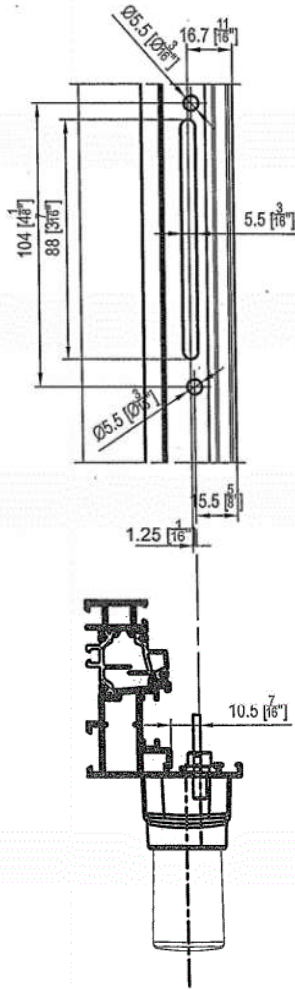

Machinable profiles: NC71003 - NC71006 - NC71012 - NC71014



DS-SAD-0239-13 revE

The results relate only to the product(s) in this report. This report shall not be reproduced, except in full, without the written approval of CLEB laboratory Inc



Machining for hardware housing  
Fin removal on frame

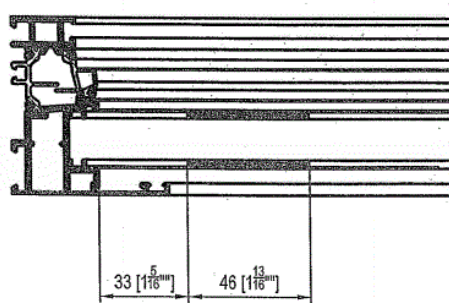
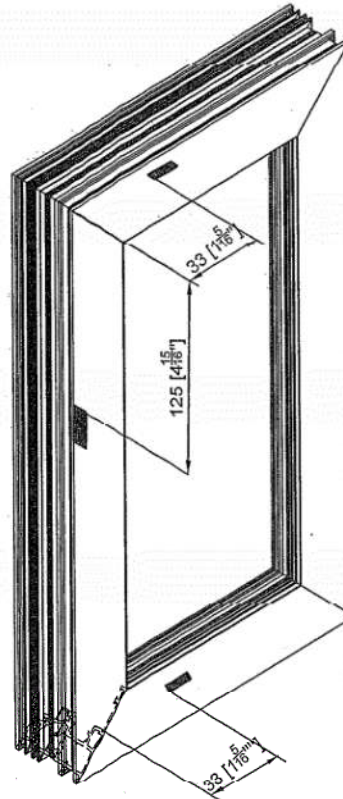
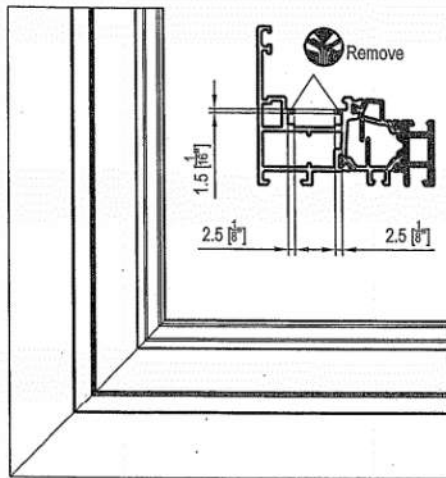

For the choice of the hardware and the handles refer to the specific documentation



Machinable profile: NC71003 - NC71006 - NC71012 - NC71014

DS-SAD-0239-13 revE

The results relate only to the product(s) in this report. This report shall not be reproduced, except in full, without the written approval of CLEB laboratory Inc



Machining for hinge MA6437 on frame

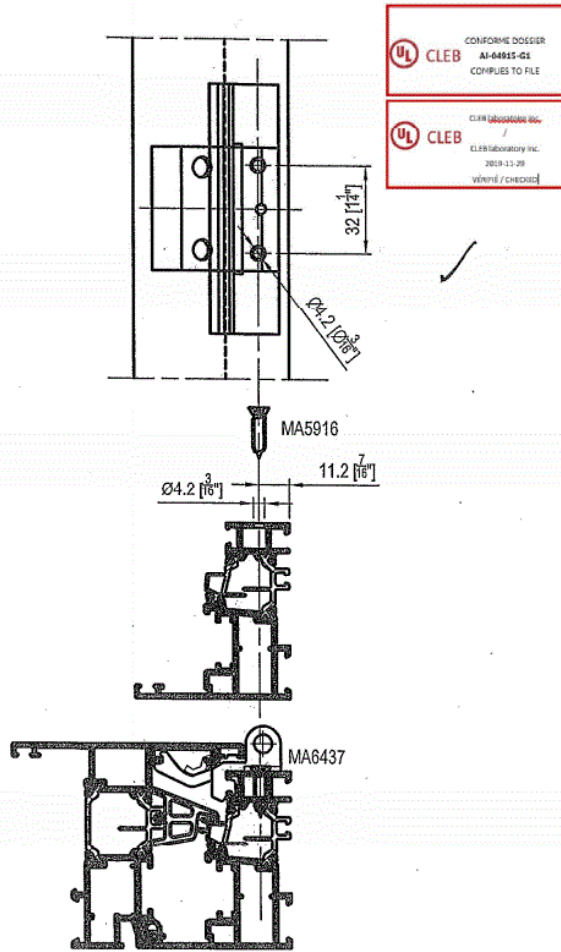

DS-SAD-0239-13 revE

The results relate only to the product(s) in this report. This report shall not be reproduced, except in full, without the written approval of CLEB laboratory Inc



# MACHINING FOR ASSEMBLY

DS-SAD-0239-13 revE

*The results relate only to the product(s) in this report. This report shall not be reproduced, except in full, without the written approval of CLEB laboratory Inc*





Corner key fixing for corner assembly

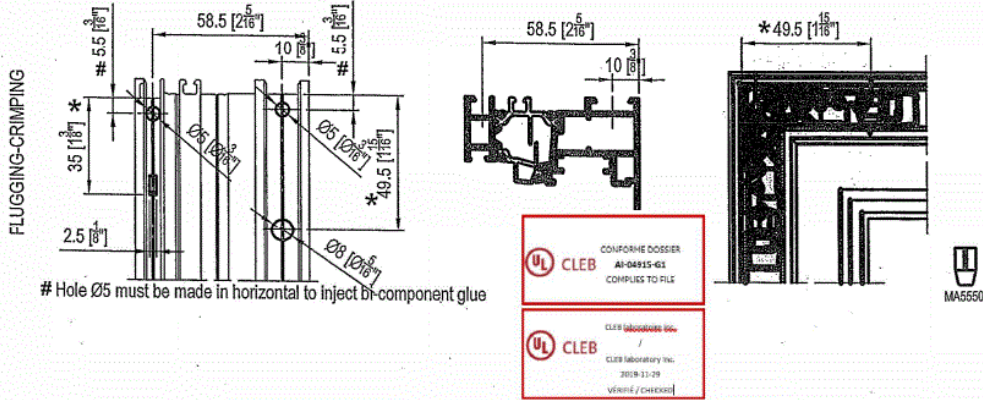

SMALL FRAME

<p>External corner key</p>	Internal corner key	MA2807
	Internal pin	MA5550
	External corner key	MA2806
	External pin	MA8250
<p>Internal corner key</p>	NC71003	

\* CHECK THE THEORETICAL DIMENSION DURING THE FABRICATION PHASE



Scale 1:2

DS-SAD-0239-13 revE

The results relate only to the product(s) in this report. This report shall not be reproduced, except in full, without the written approval of CLEB laboratory Inc



Corner key fixing for corner assembly

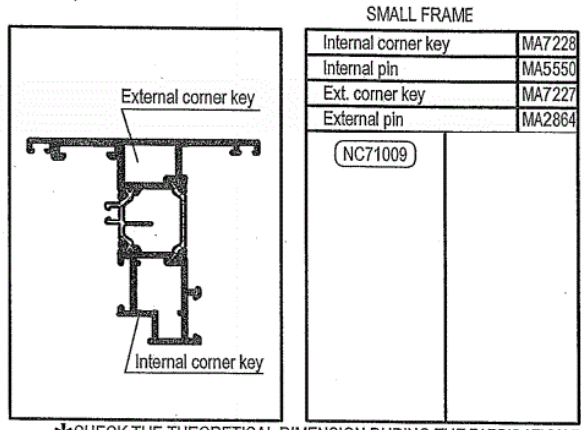
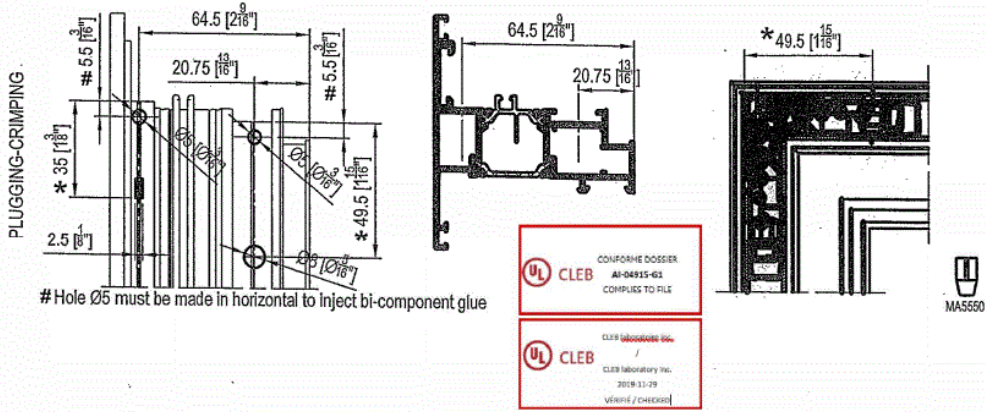

\*CHECK THE THEORETICAL DIMENSION DURING THE FABRICATION PHASE

Scale 1:2

DS-SAD-0239-13 revE

The results relate only to the product(s) in this report. This report shall not be reproduced, except in full, without the written approval of CLEB laboratory Inc



NC 65 STH HES OUT



Position of the water drainage  
 Frames  
 Solution with awning or casement opening

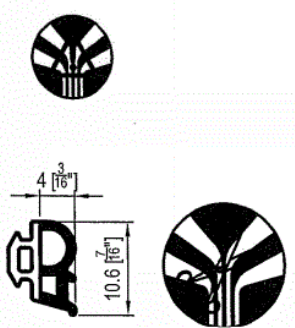
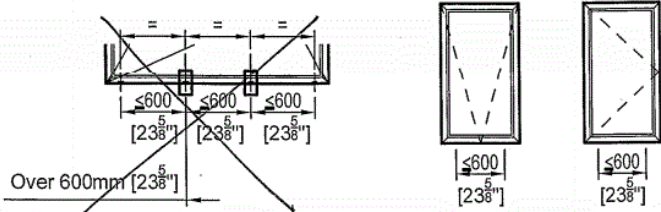

UL CLEB CONFORME DOSSIER AI-04915-G1 COMPLIUS TO FILE

UL CLEB CLEB LABORATORY INC. / CLEB LABORATORY INC. 2019-11-29 VISUAL / CHECKED

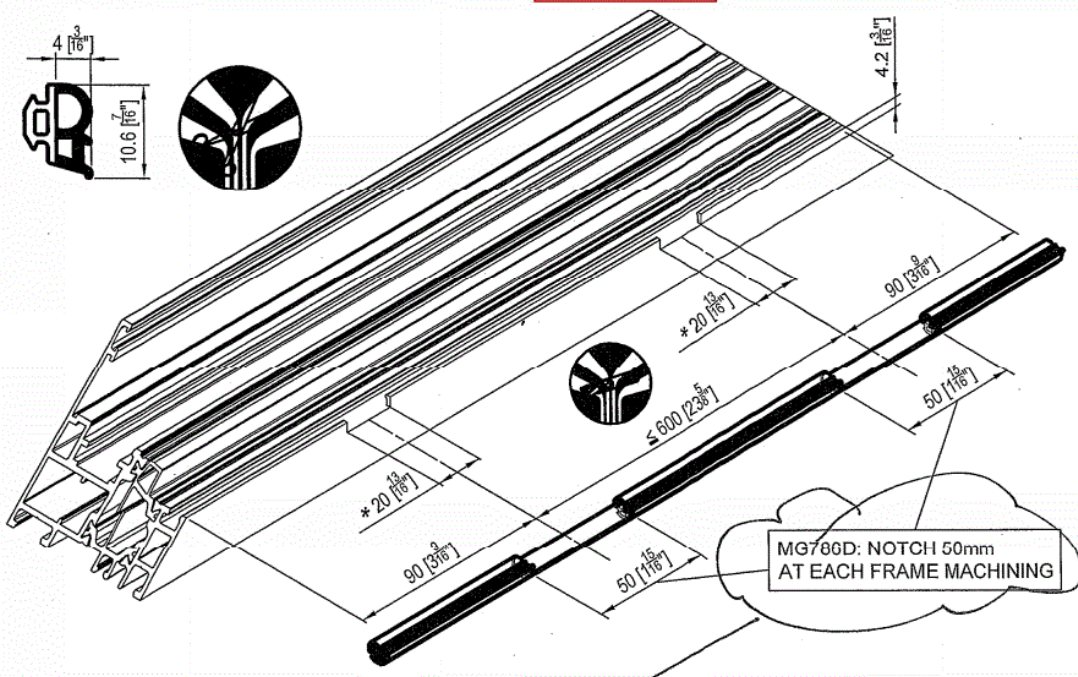

3 NOTCHES ON FRAME  
 3 NOTCHES IN GASKET

\*DRAINAGE PATH

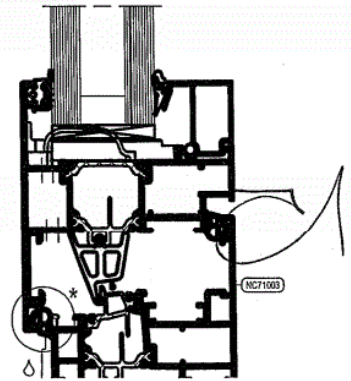

The results relate only to the product(s) in this report. This report shall not be reproduced, except in full, without the written approval of CLEB laboratory Inc



Ventilation Sashes

COMPOSITE WINDOW  
AI-04915-G1  
COMPLIES TO FILE

CLIF Manufacturing Inc.  
CLIF Manufacturing Inc.  
2019-11-29  
VENUE / CHECKED

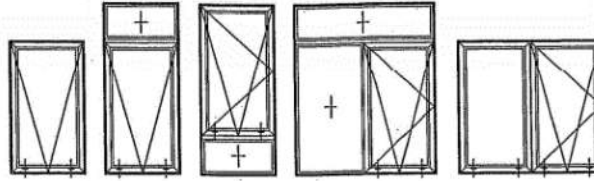

Machining to be carried out for awning as well as casement windows

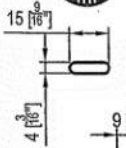

\*Carry out the internal slot by means of end mill

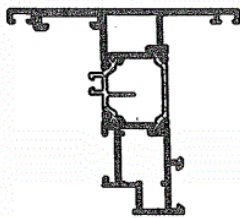
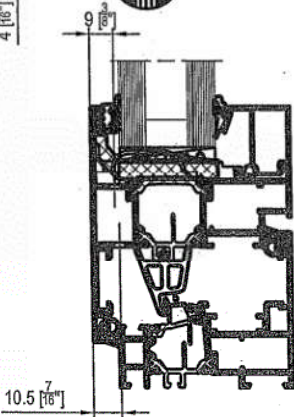

NC71009

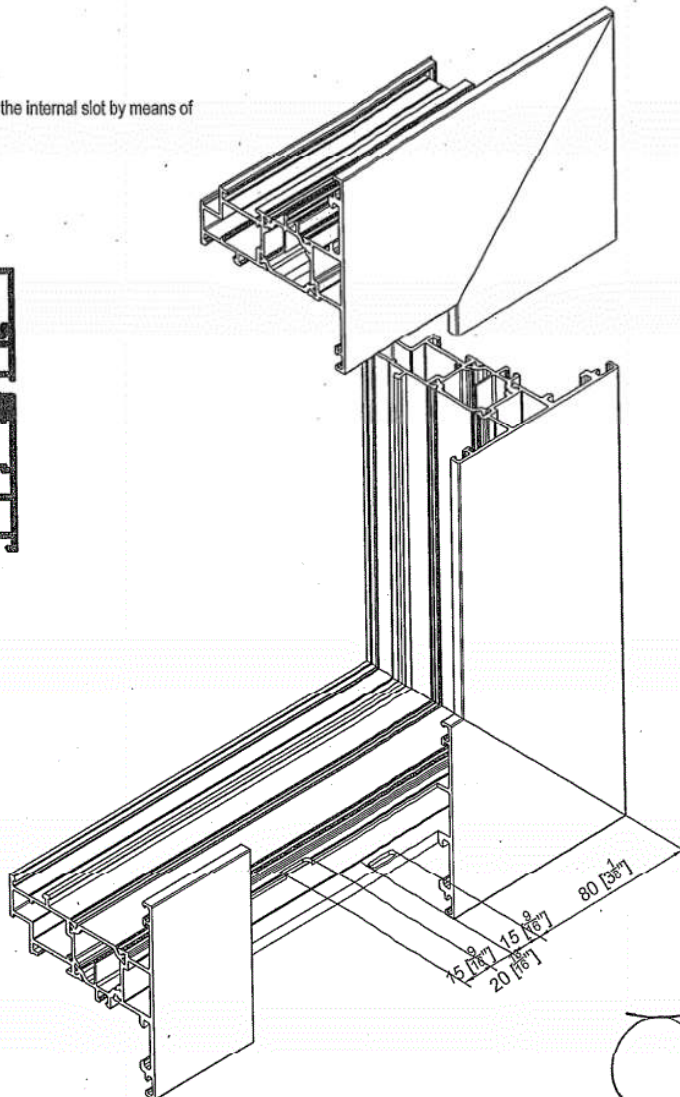

DS-SAD-0239-13 revE

The results relate only to the product(s) in this report. This report shall not be reproduced, except in full, without the written approval of CLEB laboratory Inc



Pressure compensation position  
Sashes

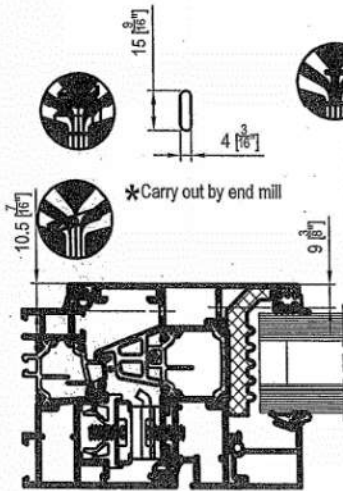
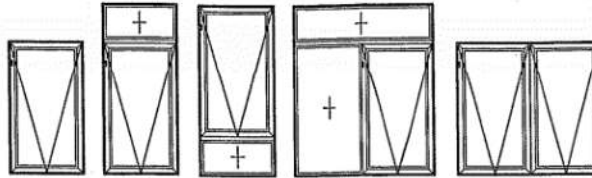

Machining to be carried out for awning as well as casement windows



Always on hinge side

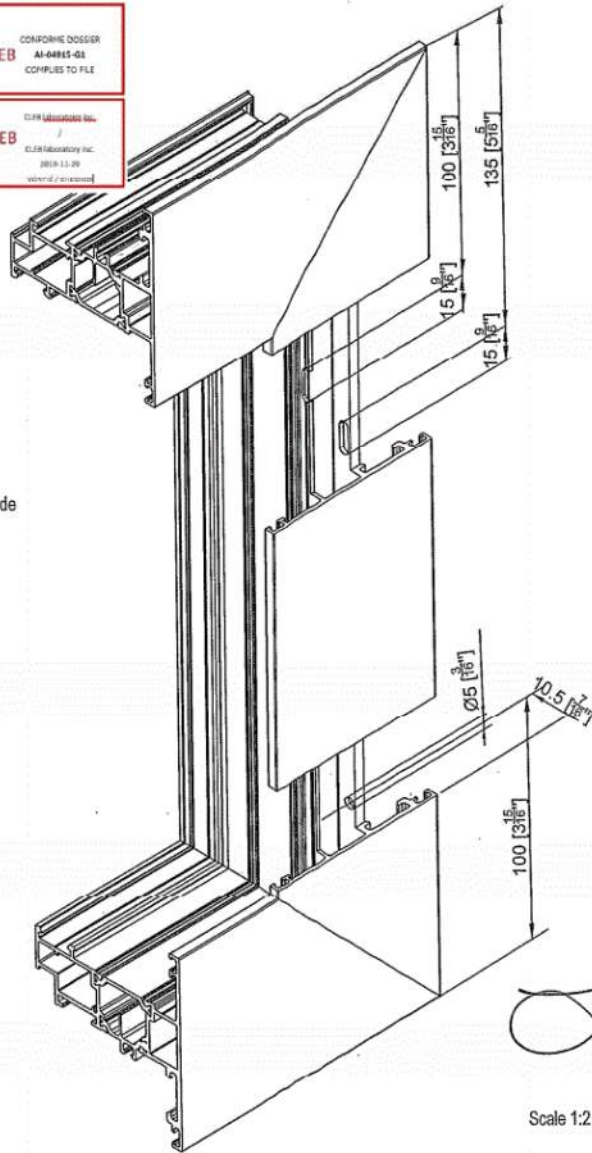
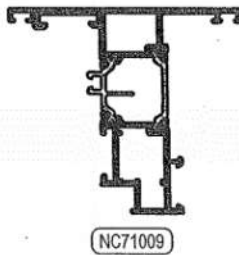

Scale 1:2

DS-SAD-0239-13 revE

The results relate only to the product(s) in this report. This report shall not be reproduced, except in full, without the written approval of CLEB laboratory Inc





Fin removal for hardware passage  
Machining on sash

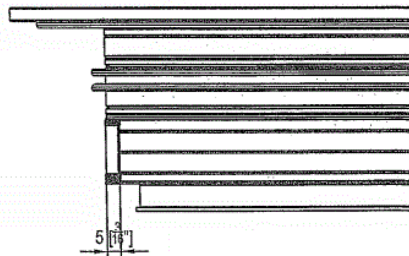
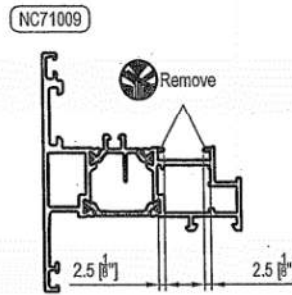
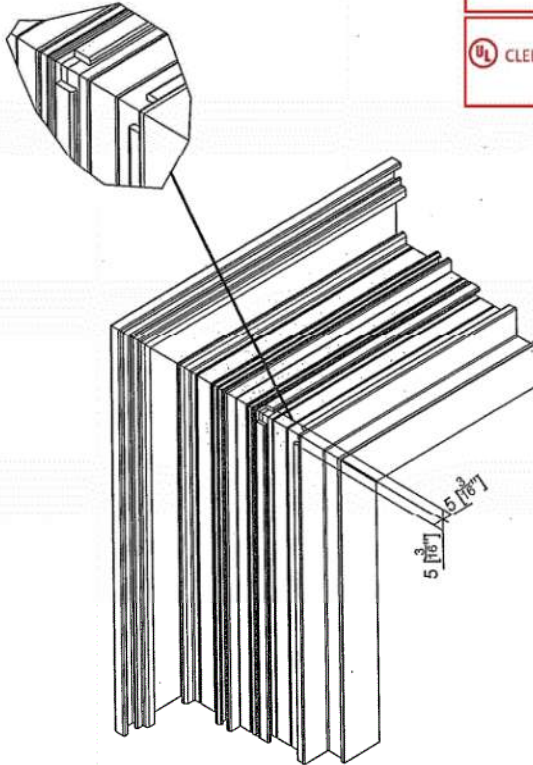

DS-SAD-0239-13 revE

The results relate only to the product(s) in this report. This report shall not be reproduced, except in full, without the written approval of CLEB laboratory Inc



Application of alignment corner key MA4081  
Frame/Frame

① Insert the corner key before the assembling of the corner

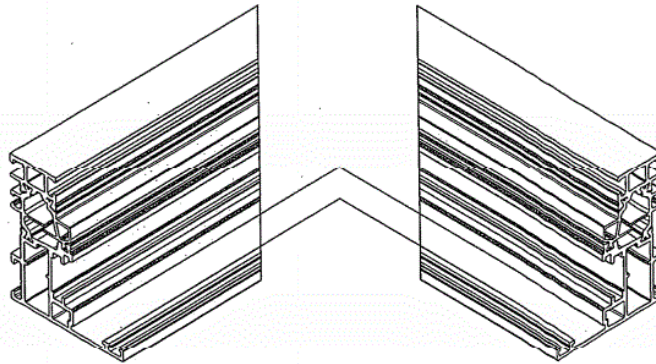

② Assemble the corner

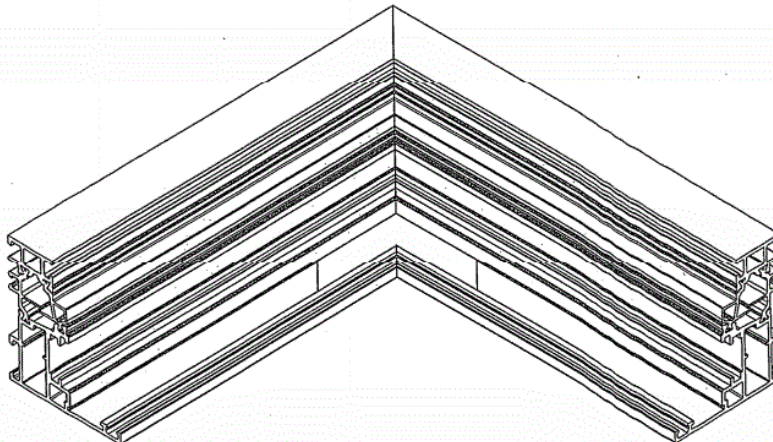

DS-SAD-0239-13 revE

The results relate only to the product(s) in this report. This report shall not be reproduced, except in full, without the written approval of CLEB laboratory Inc



Application of alignment corner key MA2811  
Sash

3

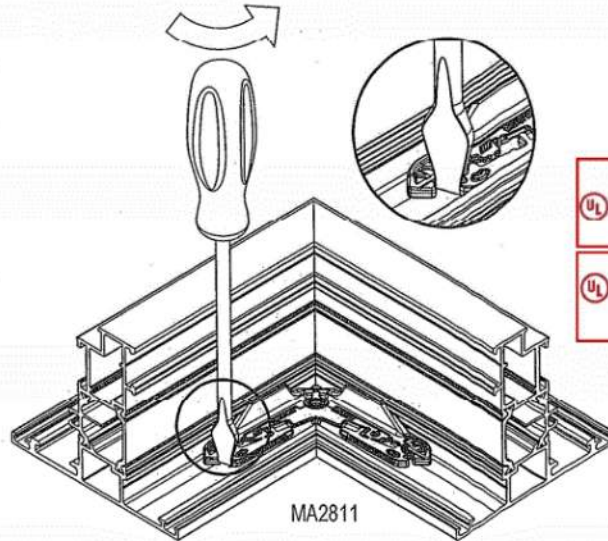

Rotate the screw driver in order to unplug the part from the main body and push it forward. Carry out the same operation on the opposite side to center the corner key in the profile.

4

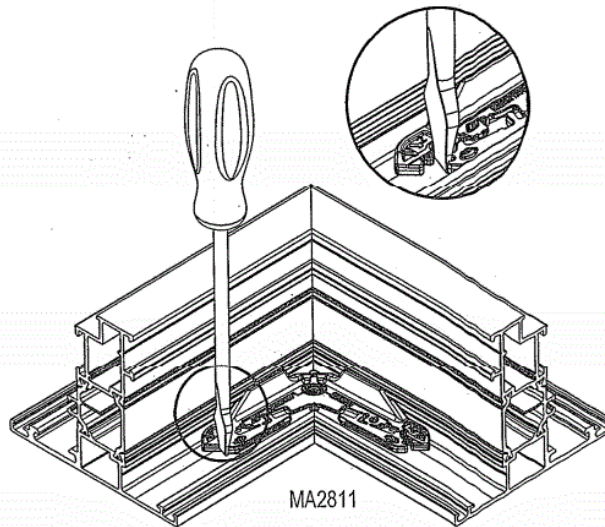

Position a screw driver 1.2x6.5 into the seat indicated by the number 2

DS-SAD-0239-13 revE

The results relate only to the product(s) in this report. This report shall not be reproduced, except in full, without the written approval of CLEB laboratory Inc





Application of alignment corner key MA2811  
Sash

5

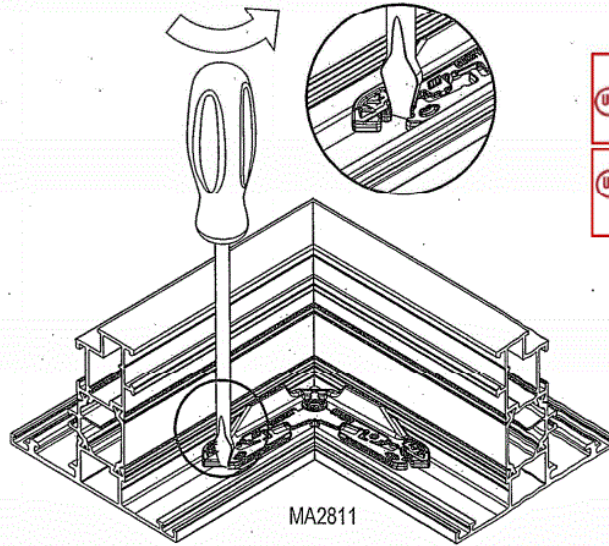

Rotate the screw driver and fix the corner key.  
Carry out the same operation on the opposite side.

6

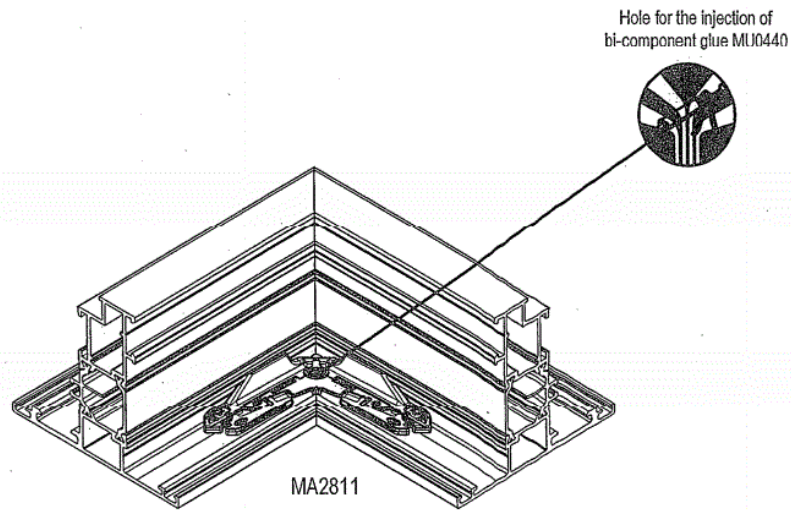

Apply bi-component glue MU0440 being careful not to let it come out of the corner key.

DS-SAD-0239-13 revE

The results relate only to the product(s) in this report. This report shall not be reproduced, except in full, without the written approval of CLEB laboratory Inc



Gasket fitting on frame  
MG786D

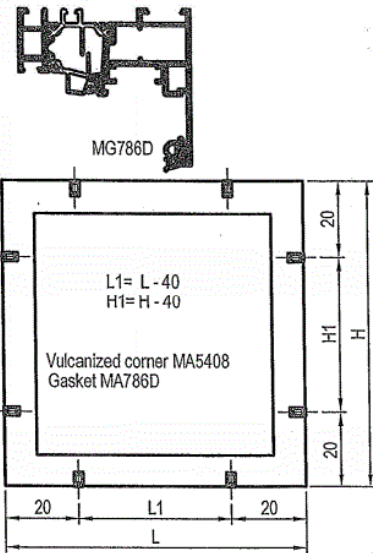
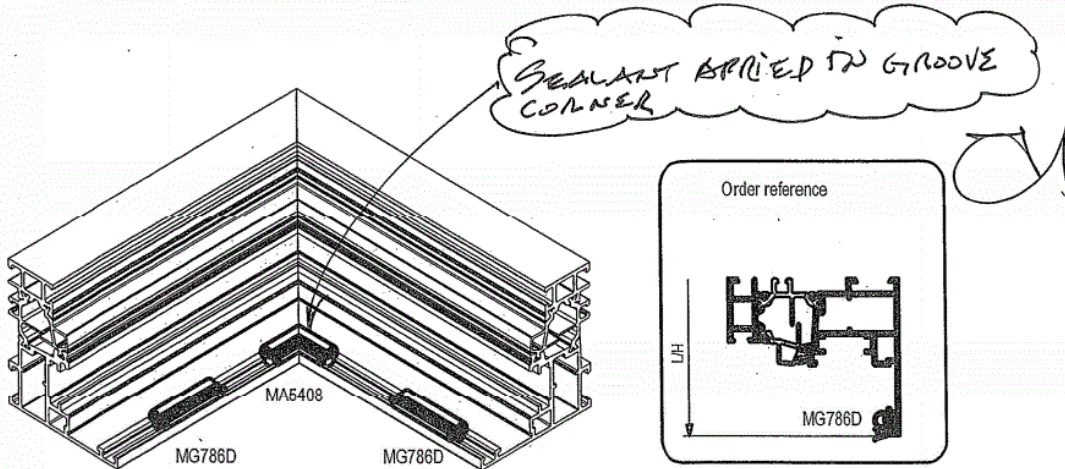

0mm < L1 or H1 > 1000 [39.3"]	cut	+6 mm -0 mm	
1000 [39.3"] < L1 or H1 > 2000 [78.7"]	cut	+10 mm -0 mm	
L1 or H1 > 2000 [78.7"]	cut	+0.5% 0	

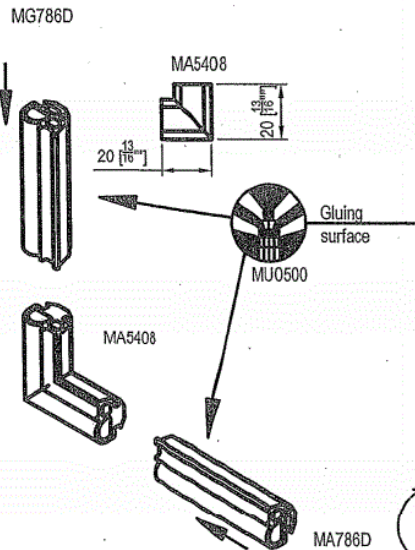

DS-SAD-0239-13 revE

The results relate only to the product(s) in this report. This report shall not be reproduced, except in full, without the written approval of CLEB laboratory Inc



Gasket fitting on frame  
MG796D

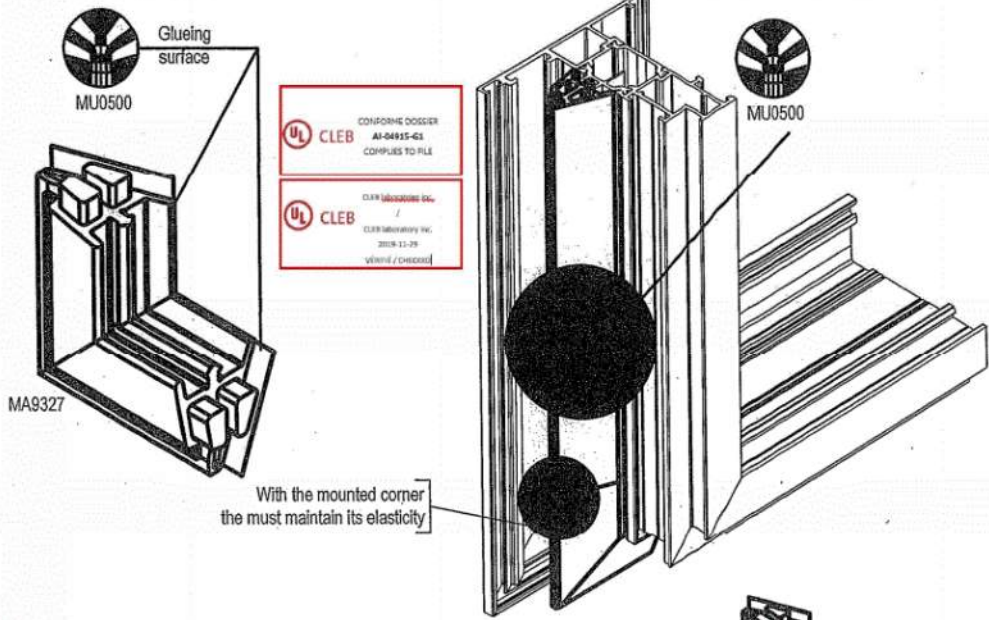

Glue perfectly the hook of the gasket

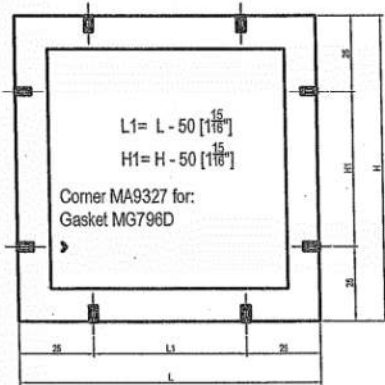

0mm < L1 or H1 > 1000 [39 3/8"]	cut	+6 mm [1/4"] -0 mm
1000 [39 3/8"] < L1 or H1 > 2000 [78 7/8"]	cut	+10 mm [3/8"] -0 mm
L1 or H1 > 2000 [78 7/8"]	cut	+0,5% -0

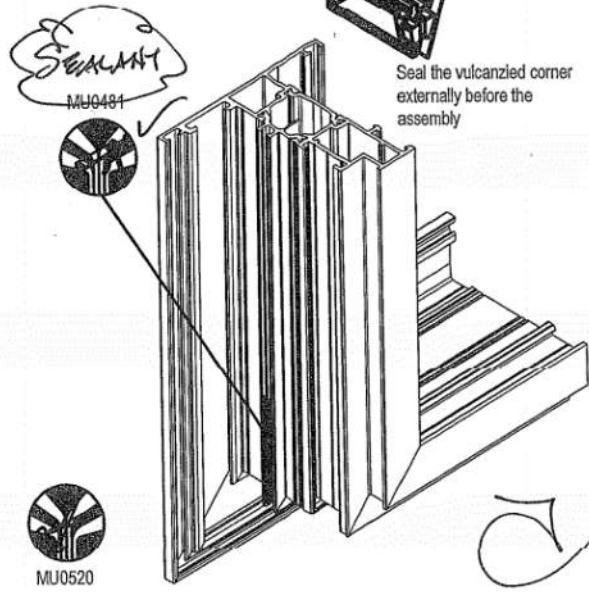

DS-SAD-0239-13 revE

The results relate only to the product(s) in this report. This report shall not be reproduced, except in full, without the written approval of CLEB laboratory Inc



Gasket fitting on sash  
MG786D

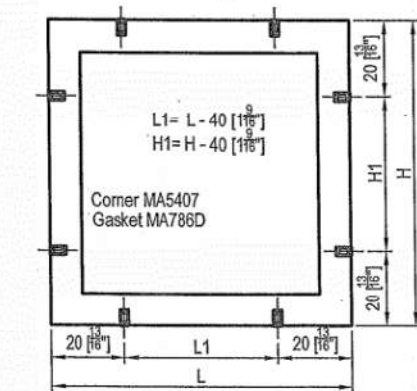
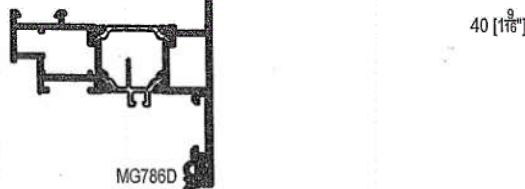
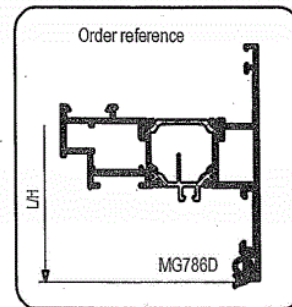
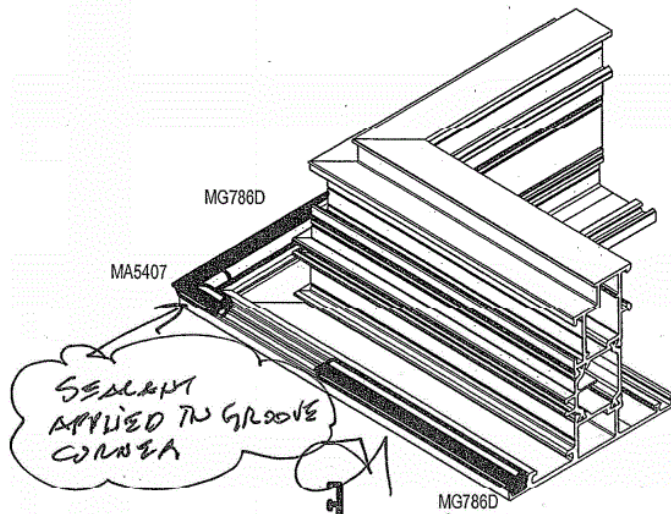

0mm < L1 or H1 > 1000 [39 3/8\"/>
1000 [39 3/8\"/>
L1 or H1 > 2000 [78 7/8\"/>

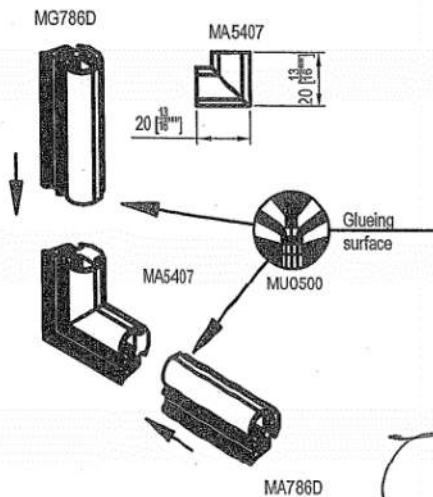

DS-SAD-0239-13 revE

The results relate only to the product(s) in this report. This report shall not be reproduced, except in full, without the written approval of CLEB laboratory Inc



Stroke end profile  
NC71015 machining and position detail

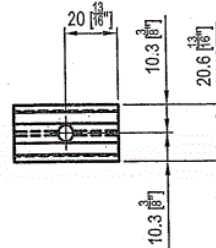
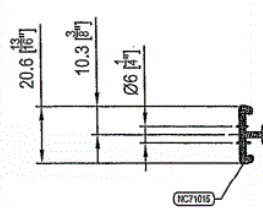
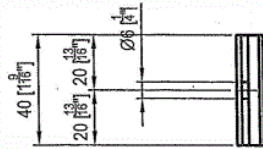

ST5.5 x 22 - C - H

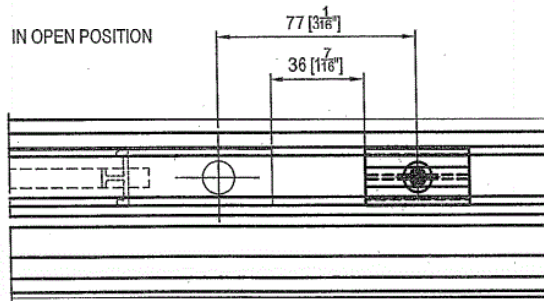
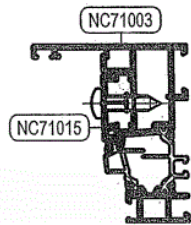
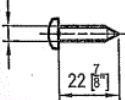

ST5.5 x 22

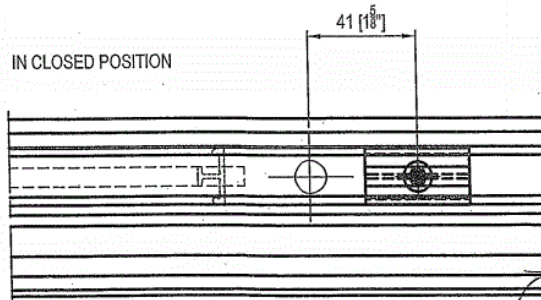
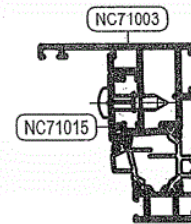
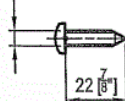

DS-SAD-0239-13 revE

The results relate only to the product(s) in this report. This report shall not be reproduced, except in full, without the written approval of CLEB laboratory Inc

# NC 65 STH HES OUT AWNING & CASEMENT WINDOWS

04/11/2019

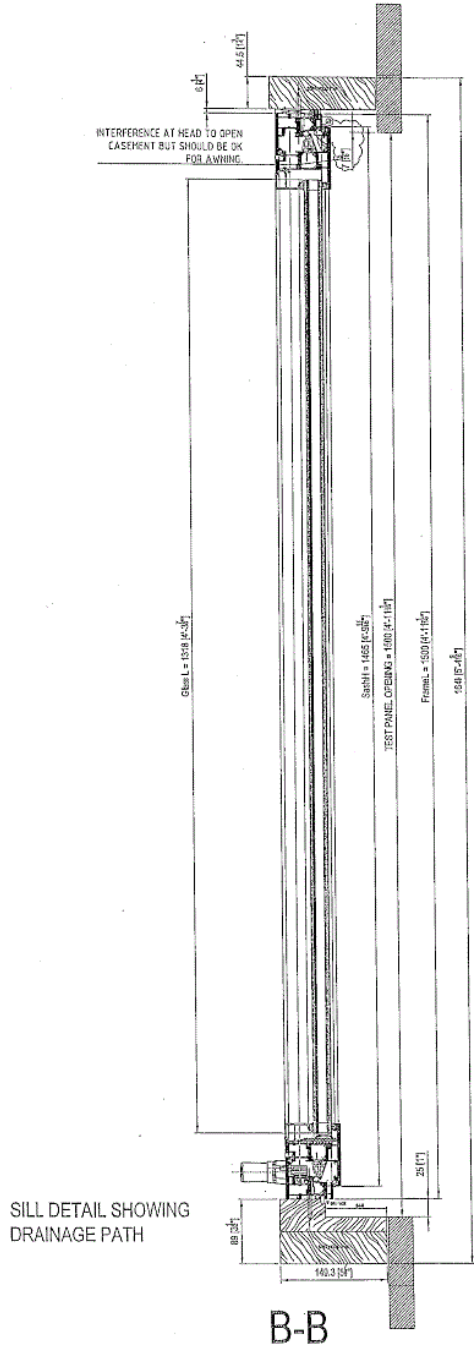

*[Handwritten signature]*

The results relate only to the product(s) in this report. This report shall not be reproduced, except in full, without the written approval of CLEB laboratory Inc



## Cleaning and maintenance of aluminium windows and doors

### Window/door maintenance

In addition to the cleaning of the profiles, you are also required to periodically perform maintenance on the seals and accessories, as well as check for any signs of wear or damage.

 Note: Any eventual adjustments or replacements of worn or damaged window/door parts must be performed exclusively by competent persons.

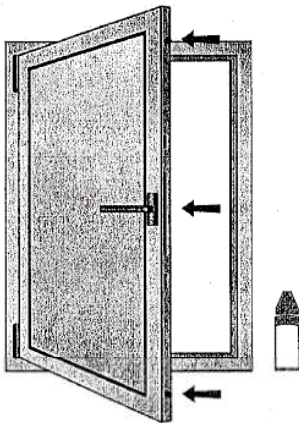

#### 1) Lubricating product for equipment

The mobile parts and all of the closing points must be lubricated.

The product leaves a protective film on all the parts that have been treated, thus movement is improved and aggravating squeaks are minimised.

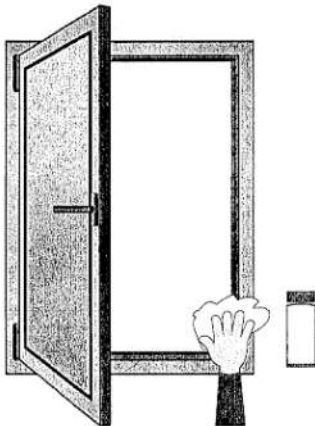

#### 2) Product for the seals

By rubbing down the seal with the designated stick and cloth, the seals maintain the correct level of elasticity.

